

## SYSTEM

The MAIHAK Shaft Power Meter is using the vibrating string measurement method for the torque measurement. The shaft speed and rotation direction is measured with two mutual combined methods (gyroscope and hall sensor). The display unit processes these measurements and calculates the resulting shaft power.

If a shaft generator is used, the system is able to take this into account, independent of the mounting position on the shaft. Additional data input as well as data output to other systems (i.e. AMS) with analog and digital interfaces is possible. Additional display units can be connected directly via existing ships network on different locations (i.e. wheelhouse). All display units can be used for data in and output.

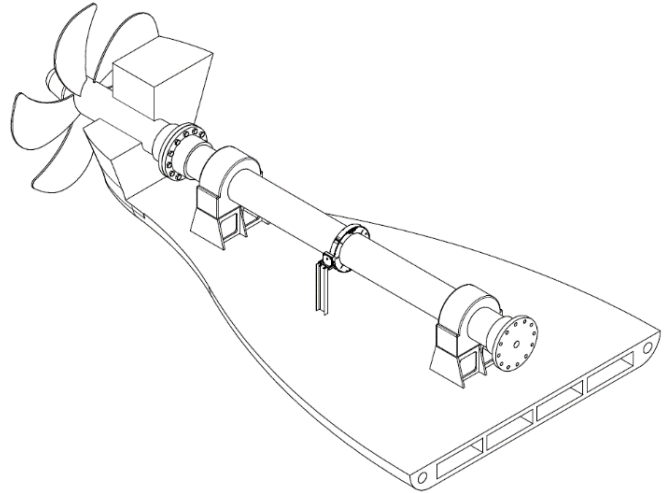

## FACTS, FEATURES & DIMENSIONS

- Minimum 500 mm mounting space on shaft (smaller mounting space upon request)
- External supply voltage 230 VAC – 50/60 Hz
- System voltage 24 VDC – 3.5 A
- Analog outputs (optional) 4-20 mA
- Data in/out (optional) 1 relay output
- Max. ambient temperature +55°C
- Shaft diameters >150 mm, suitable for FPP and CPP
- Max. shaft RPM: 350 RPM, 1000 RPM (<400 mm shaft diameter upon request)
- Measuring error approx. 0.5 % (depending on shaft diameter and torque)
- Control and measuring devices are class type-approved
- Optional remote display unit (MDS 2013) e.g. on the bridge connected via ship's network
- Connection to AMS or other systems via network or serial interface (e.g. MODBUS, NMEA) possible

Wheel House (installation of remote display in W/H is optional)

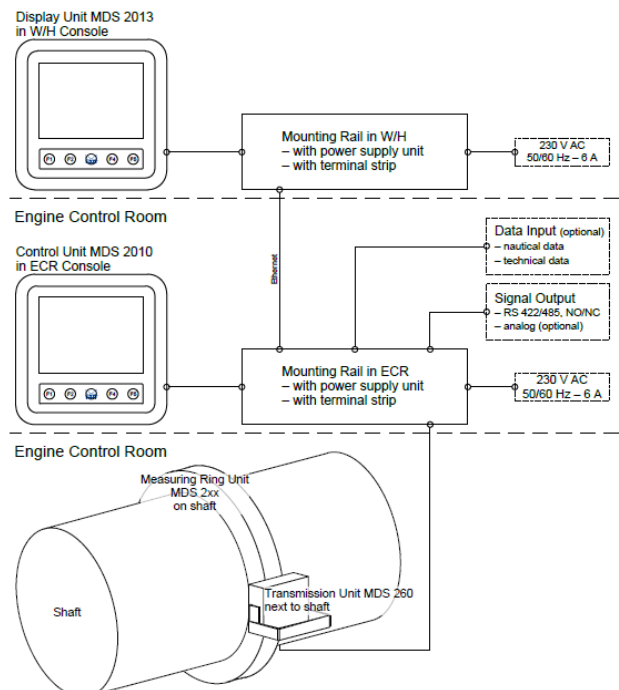

**TECHNICAL DATA MDS 31 – VIBRATION STRING SENSOR**

Zero frequency	600 Hz (default) +/- 100 Hz
Accuracy	0.2 %, temperature-compensated
Material	Stainless Steel
Max. ambient temperature	+70°C
Typical arrangement	Two sensors per shaft unit



**TECHNICAL DATA MDS 263 – SHAFT MEASURING UNIT**

Supply voltage	12 VDC (inductive)
Interfaces	Bluetooth (for communication with MDS 260)
Max. ambient temperature	+70°C
Dimensions (LxWxH)	100x48x35 mm



**TECHNICAL DATA MDS 260 – TRANSMISSION UNIT**

System voltage and current	24 VDC, 3.5 A
Interfaces	Bluetooth (for communication with MDS 263) RS-485 (for communication with PLC)
LEDs on PCB	“Status” LED (for Bluetooth connection status) “REV” LED (shaft revolution indicator) “RX”/“TX” LEDs (for PLC communication status)
Max. ambient temperature	+55°C



**TECHNICAL DATA MDS 2010 – Control Unit HOMIP 2**

Supply voltage	24 VDC
Power consumption	15 W, approx. (30 W max.)
Interfaces	2x Ethernet RJ 45 3x USB 2.0 (1x Device, 2x Host) 2x RS 422, 6x RS 485 2x CAN 500 kbit 1x SD/MMC-Card (up to 25 MB/s)
Max. operating temperature	+5°C to +55°C



**Type Approved**



**Standards, Rules and Regulations**

- GL Guidelines for the Performance of Type Approvals, Chapter 2- Test Requirements for Electrical/Electronic Equipment and Systems (VI-7-2), Edition 2012.
  - DNV-GL Class Guideline CG-0339 Edition November 2015
  - Marine, offshore and industrial applications for use in environmental categories ENV1, ENV2 and ENV3 as defined in Lloyd's Register's Type Approval System, Test Specification Number 1 – July, 2015
  - IEC 60945 Edition 2002; IEC 61162
- Please check corresponding Type Approval Certificates for details.*